

# GROVE®

## **TMS875C**



**TRUCK MOUNTED  
HYDRAULIC CRANE**

# Superstructure Specifications

## Boom (Standard)

36 ft. - 110 ft. (10.9 m - 33.5 m) four section full power boom. Equipped with remote greasing lines for upper wear pad area. Maximum Tip Height: 118 ft. (35.9 m).

## Folding Lattice Extension

### 110 ft. (33.5 m) Main boom

31 ft. or 56 ft. (9.4 m or 17 m) folding lattice swingaway extension offsettable at 1.5°, 25° or 45°. Stows alongside base boom section. Maximum Tip Height: 172 ft. (52.4 m).

### \*Boom (Optional)

40 ft. - 125 ft. (12.2 m - 38.1 m) four section full power boom. Equipped with remote greasing lines for upper wear pad area. Maximum Tip Height: 133 ft. (40.5 m).

### \*Lattice Extension

#### 125 ft. (38.1 m) Main boom

35 ft. - 60 ft. (10.7 m - 18.3 m) telescoping lattice swingaway extension offsettable at 2° or 30°. Stows alongside the base boom section. Maximum Tip Height: 191 ft. (58.2 m).

### \*Boom (Optional)

35 ft. - 138 ft. (10.8 m - 42 m) five section full power boom. Equipped with remote greasing lines for upper wear pad area. Maximum Tip Height: 147 ft. (44.8 m).

### \*Folding Lattice Extension

#### 138 ft. (42 m) Main boom

31 ft. or 56 ft. (9.4 m or 17 m) folding lattice swingaway extension offsettable at 1.5°, 25° or 45°. Stows alongside the base boom section. Maximum Tip Height: 202 ft. (61.5 m).

### \*Optional Luffing Lattice Extension

#### 138 ft. (42 m) Main boom.

31 ft. or 56 ft. (9.4 m or 17 m) folding lattice swingaway extension hydraulically offsettable from the superstructure cab. Infinite offsets 1.5° through 45°. Stows alongside the base boom section. Maximum Tip Height: 202 ft. (61.5 m).

## Boom Nose

Five nylatron sheaves (six with 125' boom), mounted on heavy duty tapered roller bearings with removable pin-type rope guards. Quick reeving type boom nose. Removable auxiliary boom nose with removable pin type rope guard.

## Boom Elevation

One double acting hydraulic cylinder with integral holding valve provides elevation from -3° to 80° (-3° to 78° with 125 ft. boom).

## Load Moment & Anti-Two Block System

Standard load moment and anti-two block system with audio-visual warning and control lever lockout. These systems provide electronic display of boom angle, boom length, radius, tip height, relative load moment, maximum permissible load, load indication and warning of impending two-block condition.

## Cab

High visibility, all steel cab with acoustical lining and tinted safety glass throughout. Deluxe seat with armrest mounted hydraulic single axis controls. Dash panel incorporates gauges for all engine functions. Other standard features include: sliding side and rear windows, hot water heat, electric windshield wash/wipe, circulating air fan, sliding skylight with sunscreen and electric skylight wiper, fire extinguisher, cup holder.

## Swing

Planetary swing with foot applied multi-disc wet brake. Spring applied, hydraulically released parking brake, plunger type mechanical house lock and 360° house lock operated from cab. Maximum speed: 2.0 RPM.

## Counterweight

8,500 lbs. (3856 kg) total consisting of (1) 5,500 lbs. (2495 kg) section and (1) 3,000 lbs. (1361 kg) section. Hydraulic installation/removal. \*Optional 9,500 lbs. (4309 kg) to be used in conjunction with standard counterweight to provide 12,500 lbs. (5670 kg) or 18,000 lbs. (8165 kg) total counterweight.

## Hydraulic System

Four main gear pumps with a combined capacity of 160 GPM (730.5 lpm). Three individual valve banks. Return line type filter with full flow by-pass protection and service indicator. Replaceable cartridge with beta rating of 5/12/16. 170 gallons (643 L) reservoir. Remote mounted oil cooler with thermostatically controlled hydraulic motor driven fan.

## Hoist specifications

Main and Auxiliary Hoists - Model HO3OG-26G

Planetary reduction with integral automatic brake, electronic hoist drum rotation indicator, hoist drum cable follower and grooved drum.

Maximum Hoist Line Pull: 17,866 lb. (8103 kg)

Maximum Rope Permissible Line Pull: 12,920 lb. (5860 kg)

Maximum Single Line Speed: 504 fpm (154 m/m)

Rope Diameter: 3/4 in. (19 mm)

Rope Length: 620 ft. (189 m)

Maximum Rope Stowage: 1,163 ft. (354 m)

*\*Denotes optional equipment*

# Carrier Specifications

## Chassis

Triple box section, four-axle carrier fabricated from high-strength, low alloy steel with towing and tie-down lugs.

## Outrigger System

Four hydraulic telescoping, two-stage, double box beam outriggers with inverted jack and integral holding valves. Quick release type outrigger floats 24 in. (610 mm) diameter. Three position setting with fully extended, intermediate (50%) extended and fully retracted capacities. Maximum outrigger pad load: 100,500 lbs. (45 587 kg).

## Outrigger Controls

Located in the superstructure cab on left side (umbilical design) and on either side of carrier with lighted boxes. Requires two hand operation. Crane level indicator (sight bubble) on right side console.

## Engine

Cummins ISM 400 diesel, six cylinders, turbo-charged after cooled, 661 cu. in. (10.8 L), 400 bhp (298 kW) (gross) @ 1500 RPM. Maximum torque 1,450 ft. lbs. (1966 Nm) @ 1200 RPM. Equipped with engine brake and audio-visual engine distress system.

## Fuel Tank Capacity

100 gallons (376 L).

## Transmission

Roadranger 11 speeds forward, 3 reverse.  
Drive 8 x 4 x 4.

## Steering

Front axle, single circuit, mechanical steering with hydraulic power assist. Turning radius: 45' 1".

## Axles

Front: (2) Eaton beam-type steering axles, 84 in. (2.13 m) track.  
Rear: (2) Eaton single reduction drive axles, 74.46 in. (1.89 m) track. Inter-axle differential locks.

## Brakes

S-cam, dual air split system operating on all wheels. Spring-applied, air released parking brake acting on rear axles.  
Air dryer.

## Suspension

Front: Walking beam with air bags and shock absorbers.  
Rear: Walking beam with air bags and shock absorbers.

## Tires

Front: 445/65R 22.5 Goodyear G286, tubeless, mounted on aluminum disc wheels.  
Rear: 315/80R 22.5 Goodyear G286, tubeless, mounted on aluminum disc wheels.

## \*Optional Tires

Front: 445/65R 22.5 Bridgestone M844F, tubeless.  
445/65R 22.5 Michelin XZY (WB), tubeless.  
Rear: 315/80R 22.5 Bridgestone M843, tubeless.  
315/80R 22.5 Michelin XZY-1 tubeless.

## Lights

Full lighting package including turn indicators, head, tail, brake, and hazard warning lights.

## Cab

One man design, all steel fabricated with acoustical lining and tinted safety glass throughout. Deluxe fabric covered seat with air height adjustment. Complete driving controls and engine instrumentation including tilt telescope steering wheel, tachometer, speedometer, voltmeter, water temp., oil pressure, fuel level, air pressure gauge with A/V warning and engine high temp./low oil pressure A/V warning. Other standard items include hot water heater/defroster, electric windshield wash/wipe, fire extinguisher, seat belt, door lock and electric window.

## Electrical System

Two 12 V - maintenance free batteries. 12 V carrier driving lights, remaining systems 24 V Standard battery disconnect.

## Maximum Speed

65 MPH (104 kph).

## Gradeability (Theoretical)

83%.

## Miscellaneous Standard Equipment

Aluminum fenders with rear storage compartments; dual rear view mirrors; electronic back-up alarm; sling/tool box; pump disconnect; tire inflation kit; air cleaner restriction indicator; block and ball stowage; and chrome package which includes aluminum wheels.

## Optional Equipment

- \*Cold Weather Package (Includes cold weather kit for main and auxiliary hoist, remote controlled heated carrier mirrors).
- \*Auxiliary Lighting Package (Includes cab mounted work lights, boom base mounted floodlights, hoist mounted work light).
- \*Flashing Light Package (Includes amber strobe for superstructure and carrier cabs).
- \*Trailing Boom Package (Includes trailer air and electrical disconnects, and trailing boom kit [less dolly]).
- \*Air conditioning, either cab.
- \*Remote controlled cab mounted work lights.
- \*Hookblocks and headache ball.
- \*Pintle hook (rear).
- \*Cross axle differential locks.
- \*Aluminum outrigger pads.
- \*Air horn.
- \*LMI light bar.
- \*PAT data logger.
- \*Grease system for turntable, air powered.
- \*On rubber load chart, including calibration.

**\*Denotes optional equipment**

# Dimensions

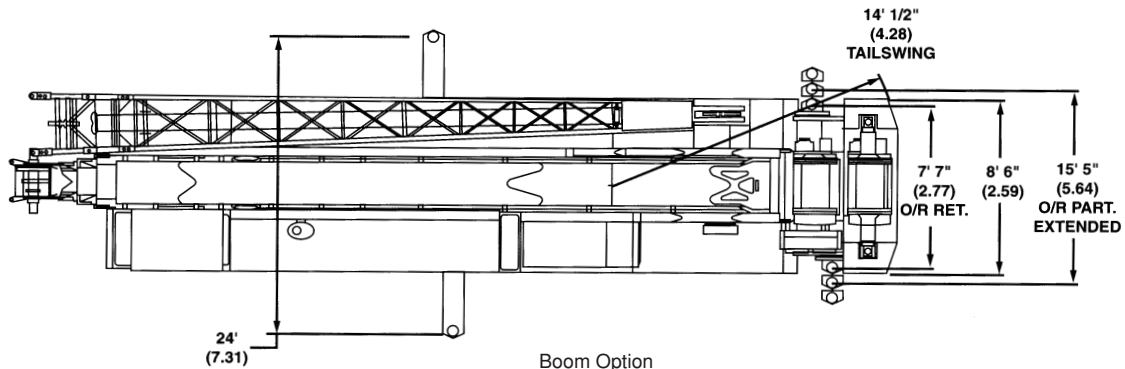

Boom Option

	110'	125'	138'
A	43' 4"	47' 5"	43' 3"
B	5' 11"	6' 0"	7' 0"
C	4' 4"	8' 5"	4' 3"

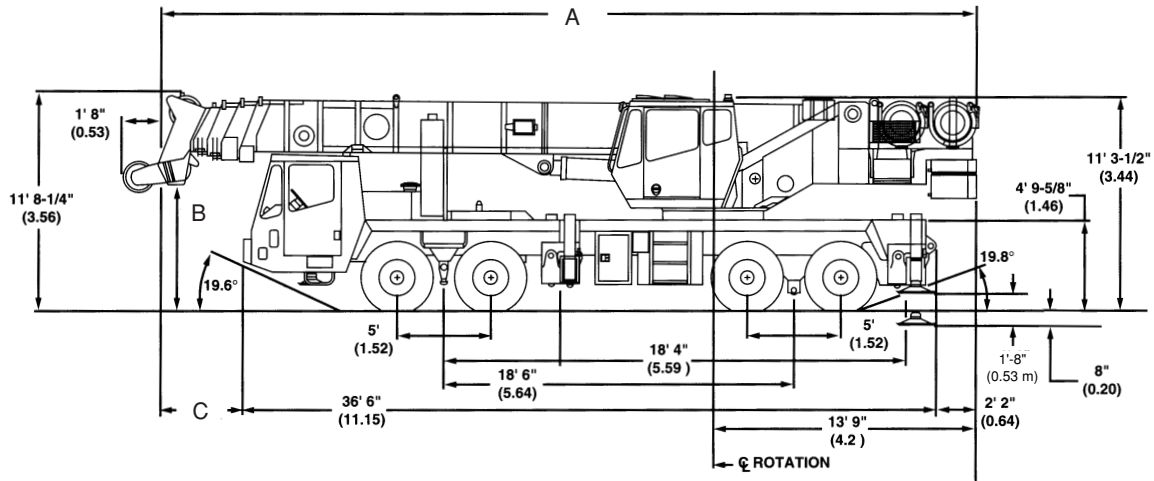

Axle/Tire Allowable Weights	GVW		Front		Rear	
	lb	kg	lb	kg	lb	kg
TMS875C Basic Machine with 110 ft. boom, main and auxiliary hoists w/ rope, and no counterweight	109,200	49,533	49,200	22,317	60,000	27,216
Add: 3,000 lb. counterweight (superstructure)	3,000	1,361	-1,353	-614	4,353	1,975
Add: 5,500 lb. counterweight (superstructure)	5,500	2,495	-2,480	-1,125	7,980	3,620
Add: 9,500 lb. counterweight (superstructure)	9,500	4,309	-4,284	-1,943	13,784	6,252
Add: 3,000 lb. counterweight (carrier)	3,000	1,361	2,704	1,227	296	134
Add: 5,500 lb. counterweight (carrier)	5,500	2,495	4,958	2,249	542	246
Add: 9,500 lb. counterweight (carrier)	9,500	4,309	8,564	3,885	936	425
Add: 75 ton, 6 sheave hookblock (stowed in trough)	1,711	776	2,443	1,108	-732	-332
Add: 45 ton, 3 sheave hookblock (stowed in trough)	830	376	1,185	538	-355	-161
Add: 10 ton headache ball (stowed in trough)	560	254	800	363	-240	-109
Substitute: 125 ft. Boom	3,970	1,801	5,100	2,313	-1,130	-515
Substitute: 138 ft. Boom	4,211	1,910	2,971	1,348	1,240	562
Remove: Auxiliary hoist cable	-775	-352	347	157	-1,122	-509
<b>110 ft. and 138 ft. Boom Options</b>						
Add: 31 ft. Fixed length extension	1,553	704	1,556	706	-3	-1
Add: 31 ft. - 56 ft. Bi-fold extension	2,240	1,016	1,973	895	267	121
Add: 31 ft. - 56 ft. Luffing bi-fold extension (138 ft. boom only)	3,122	1,416	3,298	1,496	-176	-80
Add: Auxiliary boom nose	127	58	234	106	-107	-49
<b>125 ft. Boom Options</b>						
Add: 35 ft. Fixed length extension	2,154	977	2,362	1,071	-208	-94
Add: 35 ft. - 60 ft. telescopic extension	2,893	1,312	3,172	1,439	-279	-127
Add: Auxiliary boom nose	116	53	235	107	-119	-54

# Working Range



36-110 ft.  
(10.9-33.5 m)

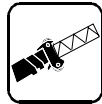

31-56 ft.  
(9.4-17 m)



18,000 lbs.  
(8165 kg)

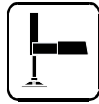

100%



360°

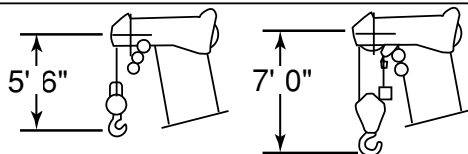
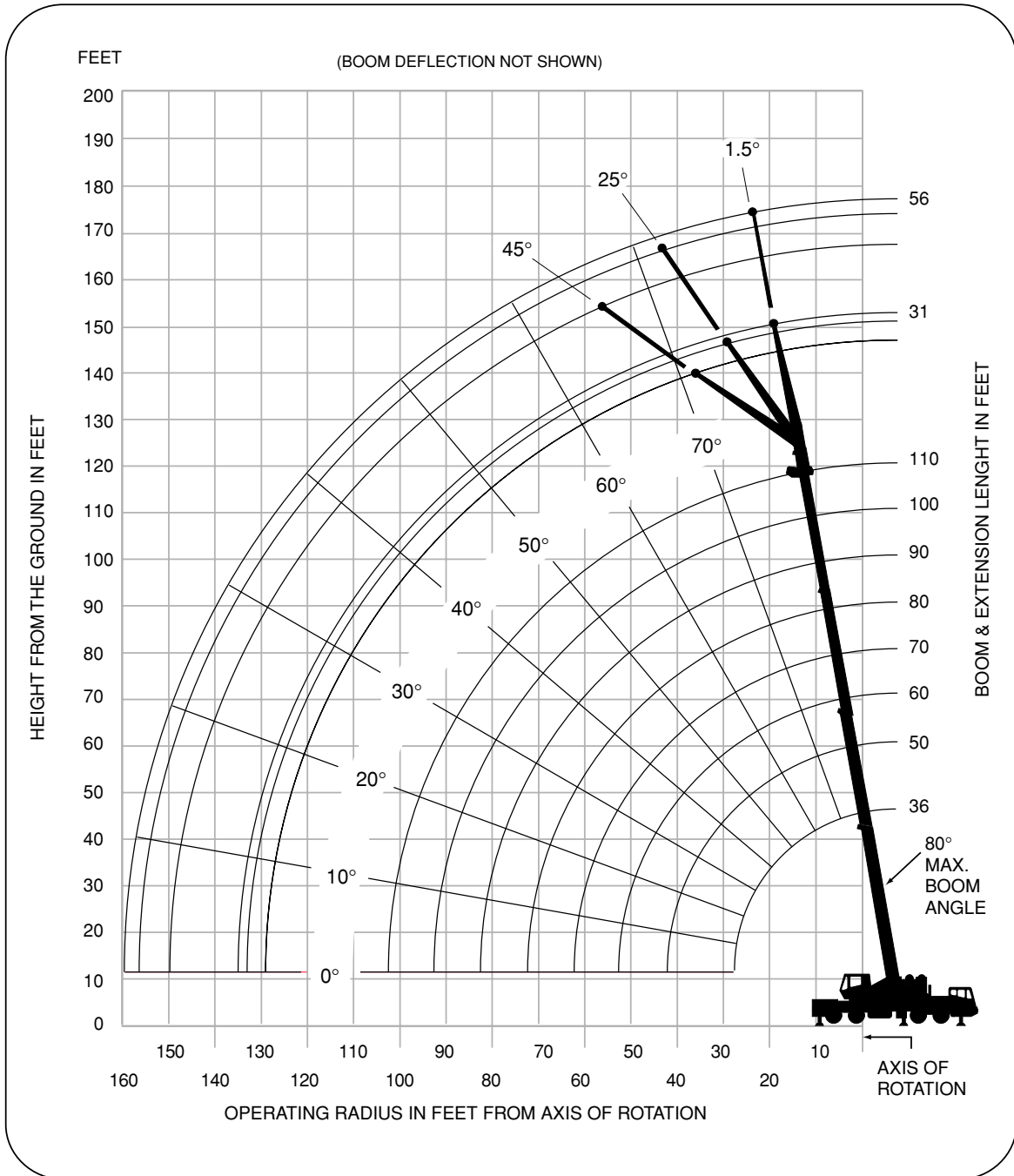

DIMENSIONS ARE FOR LARGEST GROVE FURNISHED HOOK BLOCK AND HEADACHE BALL, WITH ANTI-TWO BLOCK ACTIVATED.

# RATED LIFTING CAPACITIES IN POUNDS WITH 18,000 LB. COUNTERWEIGHT 36 FT. - 110 FT. BOOM

## ON OUTRIGGERS FULLY EXTENDED - 360°

Radius in Feet	#0501							
	Main Boom Length in Feet							
	36	50	*60	70	80	90	100	110
10	150,000+ (68)	109,500 (75)	84,200 (78)	**56,450 (80)				
12	110,500 (64)	104,500 (72.5)	79,850 (76)	56,450 (78.5)				
15	96,800 (58.5)	91,400 (69)	73,900 (73)	56,450 (76)	56,500 (78.5)	**47,850 (80)		
20	78,750 (47)	75,300 (62)	59,600 (67.5)	56,450 (71.5)	50,950 (74.5)	41,000 (77)	40,350 (79)	**27,350 (80)
25	59,800 (32.5)	59,750 (55)	50,000 (62.5)	48,900 (67)	43,800 (71)	35,250 (73.5)	34,750 (76)	27,350 (78.5)
30		47,300 (47)	42,300 (56.5)	41,900 (62.5)	38,300 (67)	31,050 (70.5)	30,450 (73)	27,350 (75.5)
35		38,550 (37.5)	36,950 (50)	36,400 (57.5)	33,900 (63)	27,650 (67)	27,000 (70)	25,300 (72.5)
40		28,450 (24.5)	28,450 (43)	29,700 (52)	30,300 (58.5)	24,350 (63)	24,250 (67)	22,900 (70)
45			23,400 (34.5)	24,650 (46.5)	25,550 (54)	22,050 (59.5)	21,900 (63.5)	20,850 (67)
50			19,450 (23)	20,700 (39.5)	21,600 (49)	20,050 (55.5)	19,950 (60)	19,100 (64)
55				17,500 (32)	18,450 (43.5)	18,350 (51)	18,300 (56.5)	17,550 (61)
60				14,900 (21)	15,850 (37.5)	16,550 (46.5)	16,850 (53)	16,200 (57.5)
65					13,650 (30)	14,350 (41.5)	14,900 (49)	15,050 (54.5)
70					11,650 (20)	12,500 (35.5)	13,050 (44.5)	13,500 (50.5)
75						10,900 (29)	11,450 (39.5)	11,900 (47)
80						9,480 (19)	10,000 (34.5)	10,500 (43)
85							8,790 (28)	9,260 (38.5)
90							7,690 (18.5)	8,150 (33)
95								7,170 (27)
100								6,280 (18.5)
Minimum boom angle (deg.) for indicated length (no load)								0
Maximum boom length (ft.) at 0 degree boom angle (no load)								110

NOTE: ( ) Boom angles are in degrees.

#LMI operating code. Refer to LMI manual for instructions.

\*\*This capacity is based on maximum boom angle.

Lifting Capacities On Outriggers Fully Extended - 360° At Zero Degree Boom Angle								
Boom Angle	Main Boom Length in Feet							
	36	50	*60	70	80	90	100	110
0°	27,600 (28.3)	16,200 (42.8)	11,350 (53.1)	9,150 (62.8)	7,410 (72.8)	6,040 (82.8)	4,950 (92.8)	4,060 (102.8)

NOTE: ( ) Reference radii in feet.

A6-829-100857

\*60 ft. boom length is with inner-mid extended and outer-mid & fly retracted.

+12 parts line required to lift this capacity (using aux. boom nose). Refer to Operator's and Safety Handbook for reeving diagram.

# 31 FT. - 56 FT. FOLDING BOOM EXTENSION WITH 18,000 LB. COUNTERWEIGHT

## ON OUTRIGGERS FULLY EXTENDED - 360°

Radius in Feet	31 FT. LENGTH			56 FT. LENGTH		
	#0521	#0522	#0523	#0541	#0542	#0543
	1.5° OFFSET	25° OFFSET	45° OFFSET	1.5° OFFSET	25° OFFSET	45° OFFSET
25	*12,900 (80)					
30	12,900 (78.5)					
35	12,900 (76.5)	8,340 (79.5)		8,220 (79.5)		
40	12,750 (74.5)	8,020 (77.5)	*6,370 (80)	8,220 (78)		
45	12,350 (72.5)	7,730 (76)	6,300 (79)	8,220 (76.5)		
50	11,500 (70.5)	7,390 (74)	6,250 (77)	8,220 (75)	*4,780 (80)	
55	10,950 (68.5)	7,130 (72)	6,190 (74.5)	8,220 (74)	4,640 (79.5)	
60	10,400 (66.5)	6,870 (69.5)	6,120 (72)	8,220 (72)	4,490 (78)	
65	9,960 (64)	6,660 (67.5)	6,090 (69.5)	8,220 (70)	4,340 (76)	*3,770 (80)
70	9,480 (61.5)	6,450 (65)	6,050 (67)	8,080 (68)	4,190 (74)	3,740 (78)
75	9,060 (59)	6,280 (62.5)	6,050 (64.5)	7,650 (66)	4,070 (72)	3,720 (76)
80	8,630 (56.5)	6,110 (60)	6,050 (62)	7,220 (64)	3,940 (70)	3,700 (73.5)
85	8,270 (54)	5,970 (57.5)	6,050 (59)	6,870 (62)	3,830 (67.5)	3,700 (71.5)
90	7,900 (51)	5,840 (54.5)	6,050 (56)	6,530 (60)	3,730 (65.5)	3,700 (69)
95	7,580 (48.5)	5,740 (51.5)		6,130 (58)	3,640 (63.5)	3,700 (66.5)
100	7,060 (45.5)	5,650 (48.5)		5,730 (55.5)	3,550 (61)	3,700 (64)
110	5,600 (38.5)	5,510 (41.5)		5,060 (51)	3,420 (56)	3,480 (59)
120	4,400 (30.5)			4,510 (46)	3,320 (51)	
130	3,400 (18.5)			4,050 (40)	3,280 (45)	
140				3,190 (33.5)	2,320 (37.5)	
150				2,460 (24.5)		
<b>No Load Stability Data</b>						
Minimum boom angle (deg.) for indicated length	2	25	45	2	25	45
Maximum boom length (ft.) at 0 deg. boom angle	110			110		

NOTE: ( ) Boom angles are in degrees.

A6-829-015081

#LMI operating code. Refer to LMI manual for operating instructions.

\*This capacity is based on maximum boom angle.

1. All capacities above the bold line are based on structural strength of boom extension and do not exceed 85% of tipping loads, in accordance with SAE J-765 NOV93.
2. 31 ft. and 56 ft. folding boom extension lengths may be used for single line lifting service only.
3. For main boom lengths less than 110 ft., rated loads are determined by boom angle. Use only the column which corresponds to the boom extension length and offset for which the machine is set up. For boom angles not shown, use rating of the next lower boom angle.
4. **WARNING:** Operation of this machine with heavier loads than the capacities listed is strictly prohibited. Machine tipping with boom extension occurs rapidly and without advance warning.
5. Boom angle is the angle above or below horizontal of the longitudinal axis of the boom base section after lifting rated load.
6. Capacities listed are with outriggers properly extended and vertical jacks set only.

THIS CHART IS ONLY A GUIDE AND SHOULD NOT BE USED TO OPERATE THE CRANE. The individual crane's load chart, operating instructions and other instructional plates must be read and understood prior to operating the crane.

# RATED LIFTING CAPACITIES IN POUNDS WITH 8,500 LB. COUNTERWEIGHT 36 FT. - 110 FT. BOOM

## ON OUTRIGGERS FULLY EXTENDED - 360°

Radius in Feet	#0001							
	Main Boom Length in Feet							
	36	50	*60	70	80	90	100	110
10	150,000+ (68)	109,500 (75)	84,200 (78)	**56,450 (80)				
12	110,500 (64)	104,500 (72.5)	79,850 (76)	56,450 (78.5)				
15	96,800 (58.5)	91,400 (69)	73,900 (73)	56,450 (76)	56,500 (78.5)	**47,850 (80)		
20	72,000 (47)	71,850 (62)	59,600 (67.5)	56,450 (71.5)	50,950 (74.5)	41,000 (77)	40,350 (79)	**27,350 (80)
25	54,450 (32.5)	54,350 (55)	50,000 (62.5)	48,900 (67)	43,800 (71)	35,250 (73.5)	34,750 (76)	27,350 (78.5)
30		42,900 (47)	42,300 (56.5)	41,900 (62.5)	38,300 (67)	31,050 (70.5)	30,450 (73)	27,350 (75.5)
35		32,300 (37.5)	32,600 (50)	33,900 (57.5)	33,900 (63)	27,650 (67)	27,000 (70)	25,300 (72.5)
40		24,300 (24.5)	25,450 (43)	26,500 (52)	27,450 (58.5)	24,350 (63)	24,250 (67)	22,900 (70)
45			20,350 (34.5)	21,200 (46.5)	22,150 (54)	22,050 (59.5)	21,900 (63.5)	20,850 (67)
50			16,300 (23)	17,250 (39.5)	18,150 (49)	19,100 (55.5)	19,450 (60)	19,100 (64)
55				14,150 (32)	15,050 (43.5)	15,950 (51)	16,300 (56.5)	16,700 (61)
60				11,600 (21)	12,600 (37.5)	13,400 (46.5)	13,800 (53)	14,150 (57.5)
65					10,550 (30)	11,400 (41.5)	11,750 (49)	12,150 (54.5)
70					8,830 (20)	9,720 (35.5)	10,050 (44.5)	10,450 (50.5)
75						8,300 (29)	8,670 (39.5)	9,060 (47)
80						7,070 (19)	7,460 (34.5)	7,850 (43)
85							6,420 (28)	6,810 (38.5)
90							5,510 (18.5)	5,900 (33)
95								5,100 (27)
100								4,390 (18.5)
Minimum boom angle (deg.) for indicated length (no load)								0
Maximum boom length (ft.) at 0 degree boom angle (no load)								110

NOTE: ( ) Boom angles are in degrees.

#LMI operating code. Refer to LMI manual for instructions.

\*\*This capacity is based on maximum boom angle.

Lifting Capacities On Outriggers Fully Extended - 360° At Zero Degree Boom Angle								
Boom Angle	Main Boom Length in Feet							
	36	50	*60	70	80	90	100	110
0°	27,600 (28.3)	16,200 (42.8)	11,350 (53.1)	9,150 (62.8)	7,410 (72.8)	6,040 (82.8)	4,950 (92.8)	4,010 (102.8)

NOTE: ( ) Reference radii in feet.

A6-829-100859

\*60 ft. boom length is with inner-mid extended and outer-mid & fly retracted.

+12 parts line required to lift this capacity (using aux. boom nose). Refer to Operator's and Safety Handbook for reeving diagram.



## 31 FT. - 56 FT. FOLDING BOOM EXTENSION WITH 8,500 LB. COUNTERWEIGHT

### ON OUTRIGGERS FULLY EXTENDED - 360°

Radius in Feet	31 FT. LENGTH			56 FT. LENGTH		
	#0021	#0022	#0023	#0041	#0042	#0043
	1.5° OFFSET	25° OFFSET	45° OFFSET	1.5° OFFSET	25° OFFSET	45° OFFSET
25	*12,900 (80)					
30	12,900 (78.5)					
35	12,900 (76.5)	8,340 (79.5)		8,220 (79.5)		
40	12,750 (74.5)	8,020 (77.5)	*6,370 (80)	8,220 (78)		
45	12,350 (72.5)	7,730 (76)	6,300 (79)	8,220 (76.5)		
50	11,500 (70.5)	7,390 (74)	6,250 (77)	8,220 (75)	*4,780 (80)	
55	10,950 (68.5)	7,130 (72)	6,190 (74.5)	8,220 (74)	4,640 (79.5)	
60	10,400 (66.5)	6,870 (69.5)	6,120 (72)	8,220 (72)	4,490 (78)	
65	9,960 (64)	6,660 (67.5)	6,090 (69.5)	8,220 (70)	4,340 (76)	*3,770 (80)
70	9,480 (61.5)	6,450 (65)	6,050 (67)	8,080 (68)	4,190 (74)	3,740 (78)
75	9,060 (59)	6,280 (62.5)	6,050 (64.5)	7,650 (66)	4,070 (72)	3,720 (76)
80	8,630 (56.5)	6,110 (60)	6,050 (62)	7,220 (64)	3,940 (70)	3,700 (73.5)
85	7,910 (54)	5,970 (57.5)	6,050 (59)	6,870 (62)	3,830 (67.5)	3,700 (71.5)
90	6,950 (51)	5,840 (54.5)	6,050 (56)	6,530 (60)	3,730 (65.5)	3,700 (69)
95	6,120 (48.5)	5,740 (51.5)		6,130 (58)	3,640 (63.5)	3,700 (66.5)
100	5,370 (45.5)	5,650 (48.5)		5,730 (55.5)	3,550 (61)	3,700 (64)
110	4,120 (38.5)	4,360 (41.5)		4,820 (51)	3,420 (56)	3,480 (59)
120	3,090 (30.5)			3,780 (46)	3,320 (51)	
130	2,240 (18.5)			2,920 (40)	3,280 (45)	
140				2,200 (33.5)	2,320 (37.5)	
150				1,580 (24.5)		
<b>No Load Stability Data</b>						
Minimum boom angle (deg.) for indicated length	2	25	45	2	25	45
Maximum boom length (ft.) at 0 deg. boom angle	110			110		

NOTE: ( ) Boom angles are in degrees.

A6-829-015083

#LMI operating code. Refer to LMI manual for operating instructions.

\*This capacity is based on maximum boom angle.

1. All capacities above the bold line are based on structural strength of boom extension and do not exceed 85% of tipping loads, in accordance with SAE J-765 NOV93.
2. 31 ft. and 56 ft. folding boom extension lengths may be used for single line lifting service only.
3. For main boom lengths less than 110 ft., rated loads are determined by boom angle. Use only the column which corresponds to the boom extension length and offset for which the machine is set up. For boom angles not shown, use rating of the next lower boom angle.
4. **WARNING:** Operation of this machine with heavier loads than the capacities listed is strictly prohibited. Machine tipping with boom extension occurs rapidly and without advance warning.
5. Boom angle is the angle above or below horizontal of the longitudinal axis of the boom base section after lifting rated load.
6. Capacities listed are with outriggers properly extended and vertical jacks set only.

THIS CHART IS ONLY A GUIDE AND SHOULD NOT BE USED TO OPERATE THE CRANE. The individual crane's load chart, operating instructions and other instructional plates must be read and understood prior to operating the crane.

# Working Range



40-125 ft.  
(12.2-38.1m)



35-60 ft.  
(10.7-18.3 m)



18,000 lbs.  
(8165 kg)



100%



360°

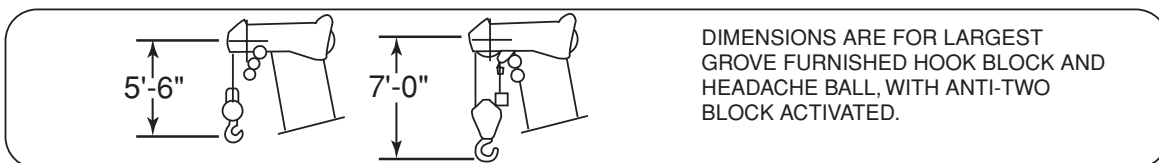
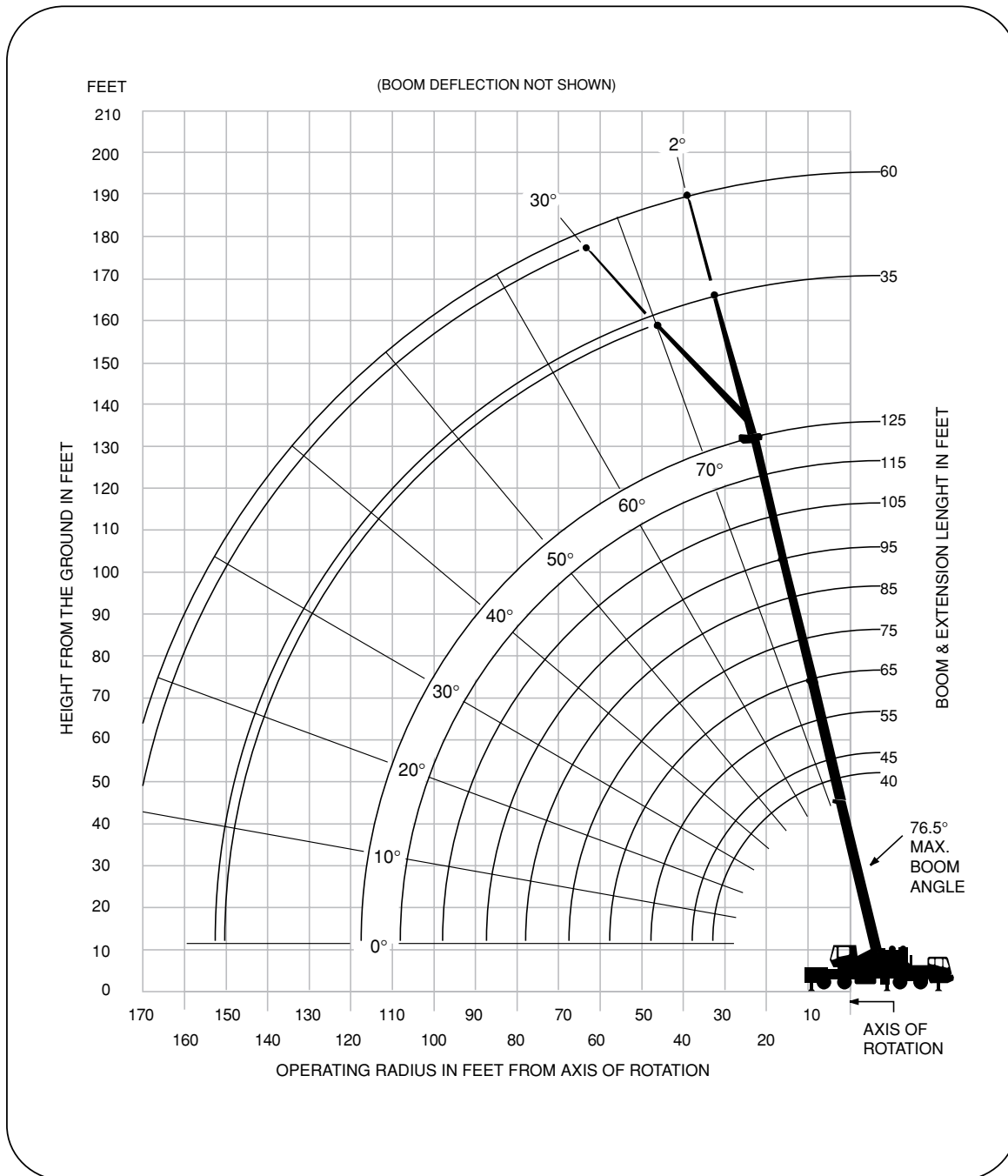

**RATED LIFTING CAPACITIES IN POUNDS WITH 18,000 LB. COUNTERWEIGHT  
40 FT. - 125 FT. BOOM**

**ON OUTRIGGERS FULLY EXTENDED - 360°**

Radius in Feet	#0001									
	Main Boom Length in Feet									
	40	45	55	65	75	85	95	105	115	125
10	+150,000 (70)	105,000 (72.5)								
12	123,500 (67)	105,000 (70)	94,600 (74)							
15	108,000 (61.5)	104,000 (65.5)	88,250 (70.5)	71,050 (74)						
20	84,200 (52.5)	83,650 (58)	76,350 (65)	60,400 (69.5)	55,250 (72.5)	48,150 (75)				
25	64,050 (41.5)	63,550 (49.5)	62,850 (58.5)	56,100 (64.5)	47,950 (68.5)	41,700 (71.5)	38,000 (73.5)	33,350 (75.5)		
30	50,750 (26)	50,350 (39.5)	49,700 (52)	48,250 (59)	41,950 (64)	36,700 (67.5)	33,300 (70.5)	30,750 (72.5)	24,550 (75)	*23,700 (76.5)
35		40,350 (26)	39,750 (44.5)	39,250 (53.5)	36,250 (59.5)	32,600 (64)	29,550 (67)	27,300 (69.5)	21,700 (72)	21,900 (74)
40			31,250 (35.5)	31,250 (47.5)	31,500 (55)	29,000 (60)	26,450 (63.5)	24,450 (66.5)	19,350 (69.5)	20,300 (71.5)
45			24,250 (23)	25,050 (40.5)	25,350 (49.5)	25,750 (55.5)	23,850 (60)	22,000 (63.5)	17,450 (66.5)	18,800 (69)
50				20,000 (32.5)	20,750 (44)	21,750 (51.5)	21,300 (56.5)	19,850 (60.5)	15,800 (64)	17,050 (66.5)
55				12,900 (21)	17,050 (38)	18,100 (46.5)	19,000 (52.5)	17,950 (57)	14,550 (61)	15,600 (64)
60					14,150 (30)	15,100 (41.5)	16,000 (48.5)	16,050 (53.5)	13,250 (58)	14,150 (61.5)
65					9,420 (19.5)	12,650 (35.5)	13,550 (44)	14,050 (50)	12,300 (55)	13,000 (58.5)
70						10,600 (28.5)	11,450 (39)	12,000 (46)	11,400 (51.5)	11,850 (55.5)
75						7,250 (18.5)	9,700 (33.5)	10,250 (42)	10,600 (48)	10,750 (52.5)
80							8,190 (27)	8,740 (37.5)	9,290 (44.5)	9,660 (49.5)
85							5,620 (17.5)	7,430 (32)	7,970 (40.5)	8,470 (46.5)
90								6,280 (25.5)	6,810 (36)	7,320 (42.5)
95								4,410 (16.5)	5,800 (31)	6,300 (39)
100									4,890 (25)	5,390 (34.5)
105									3,300 (16.5)	4,560 (30)
110										3,820 (24)
Minimum boom angle (deg.) for indicated length (no load)										0
Maximum boom length (ft. ) at 0 degree boom angle (no load)										125

NOTE: ( ) Boom angles are in degrees.

\*Based on maximum obtainable boom angle.

#LMI operating code. Refer to LMI manual for operating instructions.

+12 parts line required to lift this capacity (using aux. boom nose). Refer to Operator's and Safety Handbook for reeving diagram.

Lifting Capacities at Zero Degree Boom Angle										
Boom Angle	Main Boom Length in Feet									
	40	45	55	65	75	85	95	105	115	
0°	22,800 (32.3)	18,250 (37.8)	12,200 (47.8)	7,990 (57.8)	5,720 (67.8)	4,320 (77.8)	3,210 (87.8)	2,380 (97.8)	1,570 (107.8)	

Note: ( ) Reference radii are in feet.

A6-829-101412

# 35 FT. - 60 FT. TELE. EXTENSION WITH 18,000 LB. COUNTERWEIGHT

## ON OUTRIGGERS FULLY EXTENDED - 360°

Radius in Feet	**35 ft. LENGTH		60 ft. LENGTH	
	#0021	#0023	#0041	#0043
	2° OFFSET	30° OFFSET	2° OFFSET	30° OFFSET
40	*12,900 (76.5)			
45	11,600 (75.5)			
50	10,900 (73.5)		*6,700 (76.5)	
55	10,300 (71.5)	*7,500 (76.5)	6,320 (75)	
60	9,750 (69.5)	7,250 (74.5)	6,000 (73.5)	
65	9,250 (67.5)	7,110 (72.5)	5,630 (71.5)	
70	8,810 (65.5)	6,980 (70.5)	5,260 (70)	
75	8,400 (63.5)	6,860 (68)	4,900 (68.5)	*4,000 (76.5)
80	8,030 (61.5)	6,750 (66)	4,630 (66.5)	3,700 (74.5)
85	7,690 (59)	6,650 (64)	4,360 (65)	3,500 (72.5)
90	7,370 (57)	6,560 (61.5)	4,100 (63)	3,350 (71)
95	6,710 (54.5)	6,480 (59)	3,800 (61)	3,270 (69)
100	5,820 (52.5)	5,790 (56.5)	3,640 (59.5)	3,210 (67)
105	5,010 (50)	5,170 (54)	3,490 (57.5)	3,150 (65)
110	4,290 (47.5)	4,590 (51.5)	3,350 (55.5)	3,100 (63)
115	3,630 (44.5)	4,060 (48.5)	3,220 (53.5)	3,050 (61)
120	3,040 (41.5)	3,550 (45.5)	3,100 (51)	3,010 (58.5)
125	2,500 (38.5)	2,960 (42.5)	2,990 (49)	2,970 (56.5)
130	2,000 (35)	2,410 (39)	2,770 (47)	2,770 (54)
135	1,540 (31.5)		2,430 (44.5)	2,400 (51.5)
140	1,120 (27)		2,120 (42)	2,060 (48.5)
145			1,820 (39)	1,730 (46)
150			1,550 (36.5)	1,420 (42.5)
155			1,290 (33.5)	1,120 (39.5)

NOTE: ( ) Boom angles are in degrees.

A6-829-101454

\*This capacity is based upon maximum boom angle.

\*\*35 ft. tele. length is also applicable to 35 ft. fixed length, however, the LMI codes will change to #0051 and #0053 for the 2° and 30° offset respectively.

#LMI operating code. Refer to LMI manual for instructions.

1. All capacities above the bold line are based on structural strength of boom extension.

2. 35 ft. and 60 ft. boom extension lengths may be used for single line lifting service only.

3. Radii listed are for a fully extended boom with the boom extension erected. For main boom lengths less than fully extended, the rated loads are determined by boom angle. Use only the column which corresponds to the boom extension length and offset for which the machine is configured. For boom angles not shown, use the rating of the next lower boom angle.

**WARNING:** Operation of this machine with heavier loads than the capacities listed is strictly prohibited. Machine tipping with boom extension occurs rapidly and without advance warning.

4. Boom angle is the angle above or below horizontal of the longitudinal axis of the boom base section after lifting rated load.

5. Capacities listed are with outriggers fully extended and vertical jacks set only.

6. **35 FT. FIXED OR TELE. OFFSETTABLE BOOM EXTENSION WARNING:** For main boom length greater than 115 ft. with 35 ft. fixed or tele. boom extension in working position, the boom angle must not be less than 24° since loss of stability will occur causing a tipping condition. The boom angle is not restricted for main boom length equal to or less than 115 ft. This warning also applies for boom extension erection purposes.

**60 FT. TELE. OFFSETTABLE BOOM EXTENSION WARNING:** For main boom length greater than 105 ft. with 60 ft. tele. boom extension in working position, the boom angle must not be less than 30° since loss of stability will occur causing a tipping condition. The boom angle is not restricted for main boom length equal to or less than 105 ft. This warning also applies for boom extension erection purposes.

# RATED LIFTING CAPACITIES IN POUNDS WITH 8,500 LB. COUNTERWEIGHT 40 FT. - 125 FT. BOOM

## ON OUTRIGGERS FULLY EXTENDED - 360°

Radius in Feet	#0201									
	Main Boom Length in Feet									
	40	45	55	65	75	85	95	105	115	125
10	+150,000 (70)	105,000 (72.5)								
12	123,500 (67)	105,000 (70)	94,600 (74)							
15	108,000 (61.5)	104,000 (65.5)	88,250 (70.5)	71,050 (74)						
20	77,400 (52.5)	76,900 (58)	76,150 (65)	60,400 (69.5)	55,250 (72.5)	48,150 (75)				
25	58,650 (41.5)	58,150 (49.5)	57,500 (58.5)	56,100 (64.5)	47,950 (68.5)	41,700 (71.5)	38,000 (73.5)	33,350 (75.5)		
30	45,100 (26)	44,650 (39.5)	43,950 (52)	42,950 (59)	41,950 (64)	36,700 (67.5)	33,300 (70.5)	30,750 (72.5)	24,550 (75)	*23,700 (76.5)
35		34,450 (26)	33,650 (44.5)	32,250 (53.5)	32,800 (59.5)	32,600 (64)	29,550 (67)	27,300 (69.5)	21,700 (72)	21,900 (74)
40			26,100 (35.5)	24,850 (47.5)	25,350 (55)	26,550 (60)	26,450 (63.5)	24,450 (66.5)	19,350 (69.5)	20,300 (71.5)
45			20,700 (23)	19,500 (40.5)	19,850 (49.5)	20,950 (55.5)	22,050 (60)	22,000 (63.5)	17,450 (66.5)	18,800 (69)
50				15,450 (32.5)	15,800 (44)	16,850 (51.5)	17,850 (56.5)	18,450 (60.5)	15,800 (64)	17,050 (66.5)
55				11,700 (21)	12,700 (38)	13,650 (46.5)	14,650 (52.5)	15,200 (57)	14,550 (61)	15,600 (64)
60					10,150 (30)	11,150 (41.5)	12,050 (48.5)	12,600 (53.5)	13,100 (58)	13,600 (61.5)
65					8,130 (19.5)	9,120 (35.5)	10,000 (44)	10,500 (50)	10,950 (55)	11,450 (58.5)
70						7,380 (28.5)	8,300 (39)	8,760 (46)	9,210 (51.5)	9,650 (55.5)
75						5,920 (18.5)	6,810 (33.5)	7,290 (42)	7,720 (48)	8,140 (52.5)
80							5,540 (27)	6,030 (37.5)	6,450 (44.5)	6,850 (49.5)
85							4,440 (17.5)	4,910 (32)	5,360 (40.5)	5,740 (46.5)
90								3,940 (25.5)	4,380 (36)	4,770 (42.5)
95								3,080 (16.5)	3,510 (31)	3,910 (39)
100									2,740 (25)	3,120 (34.5)
105									2,050 (16.5)	2,430 (30)
110										1,800 (24)
Minimum boom angle (deg.) for indicated length (no load)										0
Maximum boom length (ft. ) at 0 degree boom angle (no load)										125

NOTE: ( ) Boom angles are in degrees.

\*Based on maximum obtainable boom angle.

#LMI operating code. Refer to LMI manual for operating instructions.

+12 parts line required to lift this capacity (using aux. boom nose). Refer to Operator's and Safety Handbook for reeving diagram.

Lifting Capacities at Zero Degree Boom Angle										
Boom Angle	Main Boom Length in Feet									
	40	45	55	65	75	85	95	105	115	125
0°	22,800 (32.3)	18,250 (37.8)	12,200 (47.8)	7,990 (57.8)	5,720 (67.8)	4,320 (77.8)	3,210 (87.8)	2,380 (97.8)	1,570 (107.8)	

Note: ( ) Reference radii are in feet.

A6-829-101414

# 35 FT. - 60 FT. TELE. BOOM EXTENSION WITH 8,500 LB. COUNTERWEIGHT

## ON OUTRIGGERS FULLY EXTENDED - 360°

Radius in Feet	**35 ft. LENGTH		60 ft. LENGTH	
	#0221	#0223	#0241	#0243
	2° OFFSET	30° OFFSET	2° OFFSET	30° OFFSET
40	*12,900 (76.5)			
45	11,600 (75.5)			
50	10,900 (73.5)		*6,700 (76.5)	
55	10,300 (71.5)	*7,500 (76.5)	6,320 (75)	
60	9,750 (69.5)	7,250 (74.5)	6,000 (73.5)	
65	9,250 (67.5)	7,110 (72.5)	5,630 (71.5)	
70	8,810 (65.5)	6,980 (70.5)	5,260 (70)	
75	8,400 (63.5)	6,860 (68)	4,900 (68.5)	*4,000 (76.5)
80	7,390 (61.5)	6,750 (66)	4,630 (66.5)	3,700 (74.5)
85	6,250 (59)	6,650 (64)	4,360 (65)	3,500 (72.5)
90	5,250 (57)	6,330 (61.5)	4,100 (63)	3,350 (71)
95	4,380 (54.5)	5,380 (59)	3,800 (61)	3,270 (69)
100	3,600 (52.5)	4,510 (56.5)	3,640 (59.5)	3,210 (67)
105	2,910 (50)	3,710 (54)	3,490 (57.5)	3,150 (65)
110	2,280 (47.5)	3,000 (51.5)	3,350 (55.5)	3,100 (63)
115	1,720 (44.5)	2,350 (48.5)	2,990 (53.5)	3,050 (61)
120	1,210 (41.5)	1,770 (45.5)	2,500 (51)	3,010 (58.5)
125		1,240 (42.5)	2,050 (49)	2,970 (56.5)
130			1,640 (47)	2,610 (54)
135			1,260 (44.5)	2,100 (51.5)
140				1,630 (48.5)
145				1,190 (46)

NOTE: ( ) Boom angles are in degrees.

A6-829-101456

\*This capacity is based upon maximum boom angle.

\*\*35 ft. tele. length is also applicable to 35 ft. fixed length, however, the LMI codes will change to #0251 and #0253 for the 2° and 30° offset respectively.

#LMI operating code. Refer to LMI manual for instructions.

1. All capacities above the bold line are based on structural strength of boom extension.
2. 35 ft. and 60 ft. boom extension lengths may be used for single line lifting service only.

3. Radii listed are for a fully extended boom with the boom extension erected. For main boom lengths less than fully extended, the rated loads are determined by boom angle. Use only the column which corresponds to the boom extension length and offset for which the machine is configured. For boom angles not shown, use the rating of the next lower boom angle.

**WARNING:** Operation of this machine with heavier loads than the capacities listed is strictly prohibited. Machine tipping with boom extension occurs rapidly and without advance warning.

4. Boom angle is the angle above or below horizontal of the longitudinal axis of the boom base section after lifting rated load.
5. Capacities listed are with outriggers fully extended and vertical jacks set only.

6. 35 FT. FIXED OR TELE. OFFSETTABLE BOOM EXTENSION **WARNING:** For main boom length greater than 85 ft. with 35 ft. fixed or tele. boom extension in working position, the boom angle must not be less than 39° since loss of stability will occur causing a tipping condition. The boom angle is not restricted for main boom length equal to or less than 85 ft. This warning also applies for boom extension erection purposes.

**60 FT. TELE. OFFSETTABLE BOOM EXTENSION WARNING:** For main boom length greater than 85 ft. with 60 ft. tele. boom extension in working position, the boom angle must not be less than 42° since loss of stability will occur causing a tipping condition. The boom angle is not restricted for main boom length equal to or less than 85 ft. This warning also applies for boom extension erection purposes.

# Working Range



35-138 ft.  
(10.8-42.0 m)



31-56 ft.  
(9.4-17 m)



18,000 lbs.  
(8165 kg)

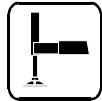

100%



360°

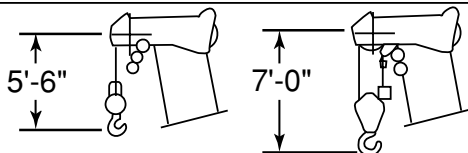
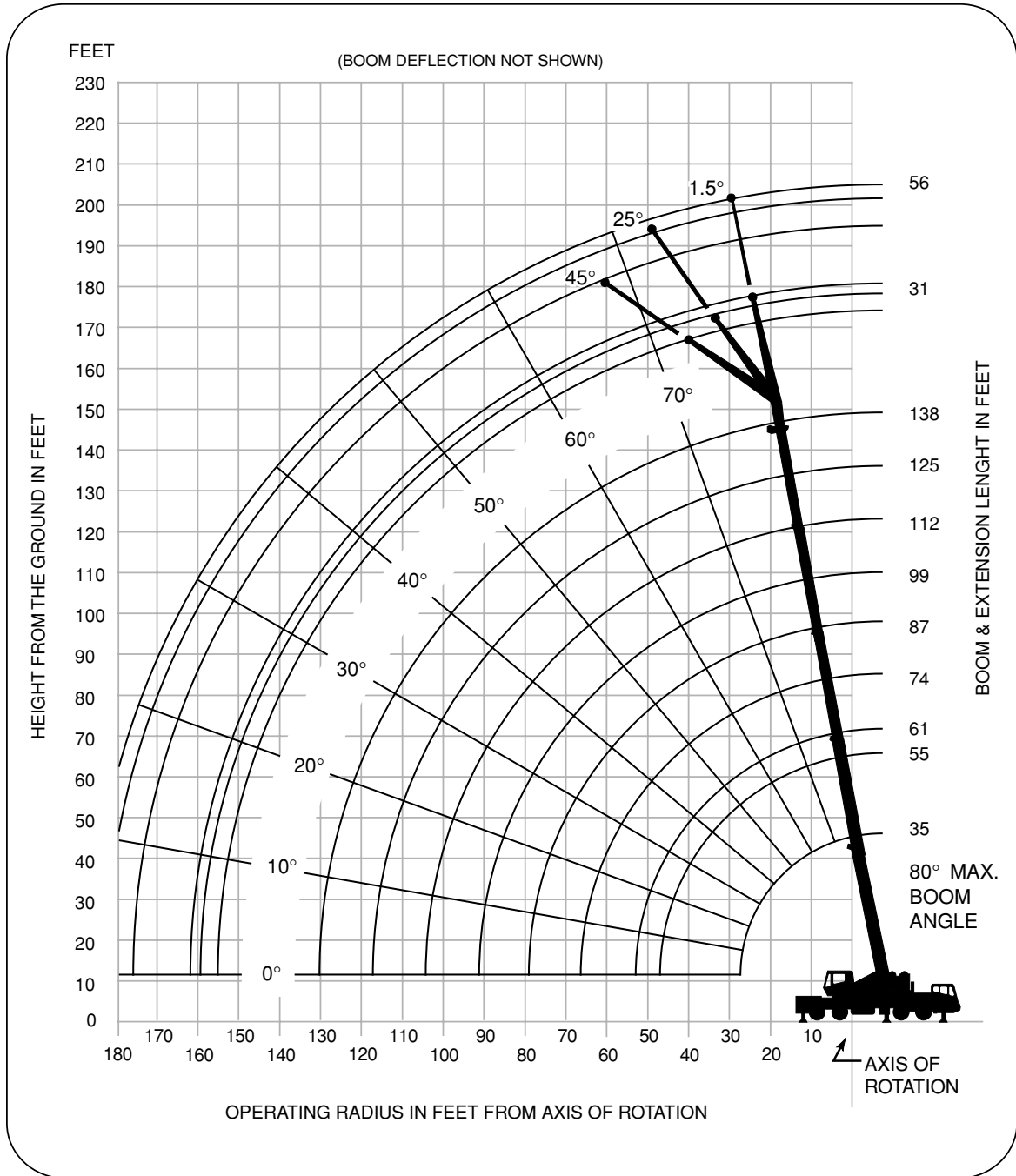

DIMENSIONS ARE FOR LARGEST GROVE FURNISHED HOOK BLOCK AND HEADACHE BALL, WITH ANTI-TWO BLOCK ACTIVATED.

# RATED LIFTING CAPACITIES IN POUNDS WITH 18,000 LB. COUNTERWEIGHT 35 FT. - 138 FT. BOOM (MODE A)

## ON OUTRIGGERS FULLY EXTENDED - 360°

Radius in Feet	<b>#0501</b>						
	Main Boom Length in Feet						
	35	61	74	87	99	112	138
10	+150,000 (65.5)	42,900 (77.5)	*32,100 (80)				
12	110,000 (62)	42,000 (75.5)	32,100 (78.5)	*31,850 (80)			
15	95,800 (56)	36,550 (72.5)	32,100 (76)	31,850 (78.5)	*21,350 (80)		
20	77,250 (44.5)	29,400 (67.5)	31,350 (71.5)	28,850 (75)	21,350 (77.5)	19,000 (79.5)	
25	58,500 (29.5)	24,350 (62)	26,450 (67.5)	25,050 (71.5)	20,850 (74.5)	18,150 (77)	*19,000 (80)
30		20,500 (56.5)	22,300 (63)	21,550 (68)	18,650 (71.5)	17,300 (74.5)	18,300 (78.5)
35		17,450 (50)	19,100 (58.5)	18,500 (64)	16,900 (68.5)	16,450 (71.5)	17,650 (76.5)
40		15,050 (43)	16,500 (53.5)	16,000 (60)	15,300 (65)	15,650 (69)	17,000 (74)
45		13,100 (35)	14,450 (48.5)	14,000 (56)	13,650 (61.5)	14,150 (66)	16,350 (72)
50		11,450 (24.5)	12,750 (42.5)	12,350 (52)	12,100 (58.5)	12,700 (63)	15,700 (69.5)
60			10,050 (28)	9,780 (42.5)	9,580 (51)	10,150 (57)	13,300 (65)
70				7,860 (30)	7,710 (42.5)	8,220 (50)	11,050 (60)
80					6,270 (32)	6,730 (42.5)	9,120 (55)
90					4,800 (15.5)	5,550 (33.5)	7,380 (49.5)
100						4,010 (21)	5,500 (43)
110							4,000 (36)
120							2,760 (27)
130							1,720 (9.5)
Minimum boom angle (deg.) for indicated length (no load)						0	9
Maximum boom length (ft.) at 0 degree boom angle (no load)						112	125

NOTE: ( ) Boom angles are in degrees.

#LMI operating code. Refer to LMI manual for instructions.

\*This capacity is based on maximum boom angle.

+12 parts line required to lift this capacity (using aux. boom nose). Refer to Operator's and Safety Handbook for reeving diagram.

<b>Lifting Capacities On Outriggers Fully Extended - 360° At Zero Degree Boom Angle</b>							
Boom Angle	Main Boom Length in Feet						
	35	61	74	87	99	112	138
0°	26,400 (28.2)	10,150 (53.8)	6,240 (66.6)	3,420 (79.4)	2,440 (92.2)	1,680 (105)	

NOTE: ( ) Reference radii in feet.

A6-829-100798

Ext. %							
Inner-mid	0	0	0	0	0	0	100
Center-mid	0	100	100	100	100	100	100
Outer-mid	0	0	25	50	75	100	100
Fly	0	0	25	50	75	100	100



# RATED LIFTING CAPACITIES IN POUNDS WITH 18,000 LB. COUNTERWEIGHT 35 FT. - 138 FT. BOOM (MODE B)

## ON OUTRIGGERS FULLY EXTENDED - 360°

Radius in Feet	#0501								
	Main Boom Length in Feet								
	35	55	61	74	87	99	112	125	138
10	+150,000 (65.5)	79,100 (76)	78,450 (77.5)	*57,050 (80)					
12	110,000 (62)	79,100 (73.5)	77,500 (75.5)	57,050 (78.5)	*43,300 (80)				
15	95,800 (56)	79,100 (70)	69,850 (72.5)	51,650 (76)	43,300 (78.5)	*32,100 (80)			
20	77,250 (44.5)	70,850 (64.5)	59,850 (67.5)	44,350 (71.5)	39,550 (75)	32,100 (77.5)	30,050 (79.5)	*20,150 (80)	
25	58,500 (29.5)	58,200 (58)	52,200 (62)	38,750 (67.5)	33,800 (71.5)	32,100 (74.5)	30,050 (77)	20,150 (79)	*19,000 (80)
30		45,850 (51)	46,200 (56.5)	34,200 (63)	29,200 (68)	30,200 (71.5)	27,350 (74.5)	19,100 (76.5)	18,300 (78.5)
35		37,100 (43.5)	37,500 (50)	29,050 (58.5)	25,800 (64)	26,600 (68.5)	24,300 (71.5)	18,100 (74)	17,650 (76.5)
40		27,050 (34.5)	27,500 (43)	25,150 (53.5)	22,900 (60)	23,450 (65)	21,600 (69)	17,250 (72)	17,000 (74)
45		22,000 (21.5)	22,450 (35)	21,800 (48.5)	20,000 (56)	20,450 (61.5)	19,250 (66)	16,450 (69)	16,350 (72)
50			18,500 (24.5)	18,550 (42.5)	17,500 (52)	17,900 (58.5)	16,900 (63)	15,750 (66.5)	15,700 (69.5)
60				12,800 (28)	12,800 (42.5)	14,000 (51)	13,250 (57)	13,100 (61.5)	13,300 (65)
70					8,830 (30)	10,150 (42.5)	10,700 (50)	10,700 (56)	11,050 (60)
80						7,160 (32)	8,240 (42.5)	8,660 (49.5)	9,120 (55)
90						4,800 (15.5)	5,870 (33.5)	6,700 (43)	7,380 (49.5)
100							4,010 (21)	4,840 (35)	5,500 (43)
110								3,340 (24.5)	4,000 (36)
120									2,760 (27)
130									1,720 (9.5)
Minimum boom angle (deg.) for indicated length (no load)									9
Maximum boom length (ft.) at 0 degree boom angle (no load)									125

NOTE: ( ) Boom angles are in degrees.

#LMI operating code. Refer to LMI manual for instructions.

\*This capacity is based on maximum boom angle.

+12 parts line required to lift this capacity (using aux. boom nose). Refer to Operator's and Safety Handbook for reeving diagram.

Lifting Capacities On Outriggers Fully Extended - 360° At Zero Degree Boom Angle									
Boom Angle	Main Boom Length in Feet								
	35	55	61	74	87	99	112	125	138
0°	26,400 (28.2)	12,500 (47.4)	10,150 (53.8)	6,240 (66.6)	3,420 (79.4)	2,440 (92.2)	1,680 (105)	1,070 (117.8)	

NOTE: ( ) Reference radii in feet.

A6-829-100803

Ext. %									
Inner-mid	0	50	50	75	100	100	100	100	100
Center-mid	0	25	50	75	100	100	100	100	100
Outer-mid	0	0	0	0	0	25	50	75	100
Fly	0	0	0	0	0	25	50	75	100

THIS CHART IS ONLY A GUIDE AND SHOULD NOT BE USED TO OPERATE THE CRANE. The individual crane's load chart, operating instructions and other instructional plates must be read and understood prior to operating the crane.

**31 FT. - 56 FT. FOLDING BOOM EXTENSION  
WITH 18,000 LB. COUNTERWEIGHT USING 125 FT. MAIN BOOM LENGTH  
ON OUTRIGGERS FULLY EXTENDED - 360°**

Radius in Feet	31 FT. LENGTH			56 FT. LENGTH		
	#0521	#0522	#0523	#0541	#0542	#0543
	1.5° OFFSET	25° OFFSET	45° OFFSET	1.5° OFFSET	25° OFFSET	45° OFFSET
30	*11,500 (80)					
35	11,500 (78.5)					
40	11,500 (77)	*10,000 (80)		6,950 (79.5)		
45	11,500 (75)	9,300 (78.5)	*8,000 (80)	6,780 (78.5)		
50	11,000 (73.5)	8,790 (76.5)	6,810 (78.5)	6,620 (77)		
60	10,050 (70)	7,960 (72.5)	6,490 (74.5)	6,290 (74)	*4,900 (80)	
70	9,220 (66)	7,360 (68.5)	6,400 (70.5)	5,960 (71)	4,560 (76.5)	*3,700 (80)
80	8,440 (62)	6,900 (64.5)	6,350 (66)	5,640 (67.5)	4,230 (73)	3,520 (76.5)
90	7,340 (57.5)	6,590 (60)	6,340 (61.5)	5,260 (64.5)	3,870 (69.5)	3,400 (72.5)
100	6,020 (53)	6,250 (55)	6,320 (56.5)	4,980 (60.5)	3,700 (65.5)	3,290 (68.5)
110	4,510 (47.5)	5,050 (50)	5,260 (51)	4,650 (56.5)	3,480 (61.5)	3,190 (64)
120	3,280 (41.5)	3,690 (44)		4,070 (52)	3,290 (57.5)	3,110 (59.5)
130	2,250 (34.5)	2,540 (36.5)		3,020 (47.5)	3,120 (52.5)	3,040 (54)
140	1,380 (26)			2,140 (42.5)	2,750 (47.5)	
150				1,380 (36.5)	1,840 (41)	
<b>No Load Stability Data</b>						
Minimum boom angle (deg.) for indicated length	24	25	45	35	37	45
Maximum boom length (ft.) at 0 deg. boom angle.	112			99		

NOTE: ( ) Boom angles are in degrees.

A6-829-014930

#LMI operating code. Refer to LMI manual for operating instructions.

\*This capacity is based on maximum boom angle.

1. All capacities above the bold line are based on structural strength of boom extension and do not exceed 85% of tipping loads, in accordance with SAE J-765 NOV93.
2. 31 ft. and 56 ft. folding boom extension lengths may be used for single line lifting service only.
3. For main boom lengths less than 125 ft. with the boom extension erected, the rated loads are determined by boom angle. Use only the column which corresponds to the boom extension length and offset for which the machine is set up. For boom angles not shown, use rating of the next lower boom angle.
4. **WARNING:** Operation of this machine with heavier loads than the capacities listed is strictly prohibited. Machine tipping with boom extension occurs rapidly and without advance warning.
5. Boom angle is the angle above or below horizontal of the longitudinal axis of the boom base section after lifting rated load.
6. Capacities listed are with outriggers properly extended and vertical jacks set only.

THIS CHART IS ONLY A GUIDE AND SHOULD NOT BE USED TO OPERATE THE CRANE. The individual crane's load chart, operating instructions and other instructional plates must be read and understood prior to operating the crane.

**31 FT. - 56 FT. FOLDING BOOM EXTENSION  
WITH 18,000 LB. COUNTERWEIGHT USING 138 FT. MAIN BOOM  
ON OUTRIGGERS FULLY EXTENDED - 360°**

Radius in Feet	31 FT. LENGTH			56 FT. LENGTH		
	#0521	#0522	#0523	#0541	#0542	#0543
	1.5° OFFSET	25° OFFSET	45° OFFSET	1.5° OFFSET	25° OFFSET	45° OFFSET
35	9,500 (79.5)					
40	9,500 (78)			*5,500 (80)		
45	9,500 (76.5)	*8,750 (80)		5,400 (79.5)		
50	9,500 (75)	7,490 (78.5)	*7,800 (80)	5,300 (78)		
60	9,110 (71.5)	7,060 (75)	6,740 (77)	5,100 (75.5)	*4,640 (80)	
70	8,450 (68.5)	6,720 (71.5)	6,460 (73.5)	4,900 (72.5)	4,430 (78)	*3,600 (80)
80	7,550 (64.5)	6,330 (68)	6,350 (69.5)	4,700 (69.5)	4,220 (74.5)	3,500 (77.5)
90	6,990 (60.5)	6,060 (64)	6,280 (65.5)	4,500 (66.5)	4,120 (71)	3,400 (74)
100	6,330 (56.5)	5,820 (60)	6,220 (61)	4,300 (63.5)	3,810 (67.5)	3,300 (70.5)
110	4,820 (52)	5,400 (55.5)	5,670 (56.5)	4,100 (59.5)	3,600 (64)	3,200 (67)
120	3,580 (47)	4,050 (50.5)	4,050 (52)	3,900 (56)	3,400 (60.5)	3,100 (63)
130	2,550 (41.5)	2,910 (45)		3,190 (52)	3,190 (56)	3,000 (58.5)
140	1,680 (35.5)	1,940 (38.5)		2,300 (47.5)	2,980 (51.5)	2,900 (53.5)
150				1,540 (42.5)	2,100 (46.5)	
160					1,300 (41)	
<b>No Load Stability Data</b>						
Minimum boom angle (deg.) for indicated length	32	32	45	40	40	45
Maximum boom length (ft.) at 0 deg. boom angle	112			99		

NOTE: ( ) Boom angles are in degrees.

A6-829-014929

#LMI operating code. Refer to LMI manual for operating instructions.

\*This capacity is based on maximum boom angle.

1. All capacities above the bold line are based on structural strength of boom extension and do not exceed 85% of tipping loads, in accordance with SAE J-765 NOV93.
2. 31 ft. and 56 ft. folding boom extension lengths may be used for single line lifting service only.
3. For main boom lengths between 125 ft. and fully extended with the boom extension erected, the rated loads are determined by boom angle. Use only the column which corresponds to the boom extension length and offset for which the machine is set up. For boom angles not shown, use rating of the next lower boom angle.
4. **WARNING:** Operation of this machine with heavier loads than the capacities listed is strictly prohibited. Machine tipping with boom extension occurs rapidly and without advance warning.
5. Boom angle is the angle above or below horizontal of the longitudinal axis of the boom base section after lifting rated load.
6. Capacities listed are with outriggers properly extended and vertical jacks set only.

THIS CHART IS ONLY A GUIDE AND SHOULD NOT BE USED TO OPERATE THE CRANE. The individual crane's load chart, operating instructions and other instructional plates must be read and understood prior to operating the crane.

**31 FT. - 56 FT. LUFFING FOLDING BOOM EXTENSION  
WITH 18,000 LB. COUNTERWEIGHT USING 125 FT. MAIN BOOM LENGTH  
ON OUTRIGGERS FULLY EXTENDED - 360°**

Radius in Feet (reference)	31 FT. LENGTH			56 FT. LENGTH		
	#5910	#5911	#5912	#5920	#5921	#5922
	1.5° OFFSET	25° OFFSET	45° OFFSET	1.5° OFFSET	25° OFFSET	45° OFFSET
30	*11,000 (80)					
35	11,000 (78.5)					
40	11,000 (77)	*10,000 (80)		6,450 (79.5)		
45	11,000 (75)	9,300 (78.5)	*8,000 (80)	6,450 (78.5)		
50	11,000 (73.5)	8,790 (76.5)	6,810 (78.5)	6,450 (77)		
60	10,050 (70)	7,960 (72.5)	6,490 (74.5)	6,290 (74)	*4,900 (80)	
70	9,220 (66)	7,360 (68.5)	6,400 (70.5)	5,960 (71)	4,560 (76.5)	*3,700 (80)
80	8,440 (62)	6,900 (64.5)	6,350 (66)	5,640 (67.5)	4,230 (73)	3,520 (76.5)
90	7,340 (57.5)	6,590 (60)	6,340 (61.5)	5,260 (64.5)	3,870 (69.5)	3,400 (72.5)
100	6,000 (53)	6,250 (55)	6,320 (56.5)	4,980 (60.5)	3,700 (65.5)	3,290 (68.5)
110	4,470 (47.5)	4,860 (50)	4,530 (51)	4,650 (56.5)	3,480 (61.5)	3,190 (64)
120	3,210 (41.5)	3,530 (44)		4,070 (52)	3,290 (57.5)	3,110 (59.5)
130	2,160 (34.5)	2,420 (36.5)		3,020 (47.5)	3,120 (52.5)	3,040 (54)
140	1,280 (26)			2,140 (42.5)	2,750 (47.5)	
150				1,350 (36.5)	1,840 (41)	
<b>No Load Stability Data</b>						
Minimum boom angle (deg.) for indicated length	24	25	45	35	37	45
Maximum boom length (ft.) at 0° boom angle	112			99		

NOTE: ( ) Boom angles are in degrees.

A6-829-100353

#LMI operating code, for reference only (does not require input - automatically displayed). Refer to LMI manual for operating instructions.

\* This capacity is based on maximum boom angle.

- Capacities are based on main boom angles in conjunction with extension offset angle. Radii are for 125' main boom length only.
- All capacities above the bold line are based on structural strength of boom extension and do not exceed 85% of tipping loads, in accordance with SAE J-765.
- 31 ft. and 56 ft. luffing folding boom extension lengths may be used for single line lifting service only.
- For main boom lengths less than 125 ft. with the boom extension erected, the rated loads are determined by boom angle. Use only the column which corresponds to the boom extension length and offset for which the machine is set up. For boom angles not shown, use rating of the next lower boom angle. For extension offset angles not shown, use rating of next greater offset angle.
- WARNING:** Operation of this machine with heavier loads than the capacities listed is strictly prohibited. Machine tipping with boom extension occurs rapidly and without advance warning.
- Boom angle is the angle above or below horizontal of the longitudinal axis of the boom base section after lifting rated load.
- Capacities listed are with outriggers properly extended and vertical jacks set only.

THIS CHART IS ONLY A GUIDE AND SHOULD NOT BE USED TO OPERATE THE CRANE. The individual crane's load chart, operating instructions and other instructional plates must be read and understood prior to operating the crane.

**31 FT. - 56 FT. LUFFING FOLDING BOOM EXTENSION  
WITH 18,000 LB. COUNTERWEIGHT USING 138 FT. MAIN BOOM  
ON OUTRIGGERS FULLY EXTENDED - 360°**

Radius in Feet (reference)	31 FT. LENGTH			56 FT. LENGTH		
	#5910	#5911	#5912	#5920	#5921	#5922
	1.5° OFFSET	25° OFFSET	45° OFFSET	1.5° OFFSET	25° OFFSET	45° OFFSET
35	9,500 (79.5)					
40	9,500 (78)			*5,500 (80)		
45	9,500 (76.5)	*8,750 (80)		5,400 (79.5)		
50	9,500 (75)	7,490 (78.5)	*7,800 (80)	5,300 (78)		
60	9,110 (71.5)	7,060 (75)	6,740 (77)	5,100 (75.5)	*4,640 (80)	
70	8,450 (68.5)	6,720 (71.5)	6,460 (73.5)	4,900 (72.5)	4,430 (78)	*3,600 (80)
80	7,550 (64.5)	6,330 (68)	6,350 (69.5)	4,700 (69.5)	4,220 (74.5)	3,500 (77.5)
90	6,990 (60.5)	6,060 (64)	6,160 (65.5)	4,500 (66.5)	4,120 (71)	3,400 (74)
100	6,250 (56.5)	5,820 (60)	5,880 (61)	4,300 (63.5)	3,810 (67.5)	3,300 (70.5)
110	4,760 (52)	5,340 (55.5)	5,470 (56.5)	4,100 (59.5)	3,600 (64)	3,200 (67)
120	3,540 (47)	3,920 (50.5)	3,960 (51)	3,900 (56)	3,400 (60.5)	3,100 (63)
130	2,530 (41.5)	2,750 (45)		3,190 (52)	3,190 (56)	3,000 (58.5)
140	1,670 (35.5)	1,750 (38.5)		2,300 (47.5)	2,980 (51.5)	2,900 (53.5)
150				1,540 (42.5)	2,100 (46.5)	
160					1,300 (41)	
<b>No Load Stability Data</b>						
Minimum boom angle (deg.) for indicated length	32	32	45	40	40	45
Maximum boom length (ft.) at 0° boom angle	112			99		

NOTE: ( ) Boom angles are in degrees.

A6-829-100347

#LMI operating code, for reference only (does not require input - automatically displayed). Refer to LMI manual for operating instructions.

\*This capacity is based on maximum boom angle.

1. Capacities are based on main boom angles in conjunction with extension offset angle. Radii are for 138' main boom length only.
2. All capacities above the bold line are based on structural strength of boom extension and do not exceed 85% of tipping loads, in accordance with SAE J-765.
3. 31 ft. and 56 ft. luffing folding boom extension lengths may be used for single line lifting service only.
4. For main boom lengths between 125 ft. and fully extended with the boom extension erected, the rated loads are determined by boom angle. Use only the column which corresponds to the boom extension length and offset for which the machine is set up. For boom angles not shown, use rating of the next lower boom angle. For extension offset angles not shown, use rating of next greater offset angle.
5. **WARNING:** Operation of this machine with heavier loads than the capacities listed is strictly prohibited. Machine tipping with boom extension occurs rapidly and without advance warning.
6. Boom angle is the angle above or below horizontal of the longitudinal axis of the boom base section after lifting rated load.
7. Capacities listed are with outriggers properly extended and vertical jacks set only.

THIS CHART IS ONLY A GUIDE AND SHOULD NOT BE USED TO OPERATE THE CRANE. The individual crane's load chart, operating instructions and other instructional plates must be read and understood prior to operating the crane.

# RATED LIFTING CAPACITIES IN POUNDS WITH 8,500 LB. COUNTERWEIGHT 35 FT. - 138 FT. BOOM (MODE A)

## ON OUTRIGGERS FULLY EXTENDED - 360°

Radius in Feet	#0001						
	Main Boom Length in Feet						
	35	61	74	87	99	112	138
10	+150,000 (65.5)	42,900 (77.5)	*32,100 (80)				
12	110,000 (62)	42,000 (75.5)	32,100 (80)	*31,850 (80)			
15	95,800 (56)	36,550 (72.5)	32,100 (76)	31,850 (78.5)	*21,350 (80)		
20	70,700 (44.5)	29,400 (67.5)	31,350 (71.5)	28,850 (75)	21,350 (77.5)	19,000 (79.5)	
25	53,150 (29.5)	24,350 (62)	26,450 (67.5)	25,050 (71.5)	20,850 (74.5)	18,150 (77)	*19,000 (80)
30		20,500 (56.5)	22,300 (63)	21,550 (68)	18,650 (71.5)	17,300 (74.5)	18,300 (78.5)
35		17,450 (50)	19,100 (58.5)	18,500 (64)	16,900 (68.5)	16,450 (71.5)	17,650 (76.5)
40		15,050 (43)	16,500 (53.5)	16,000 (60)	15,300 (65)	15,650 (69)	17,000 (74)
45		13,100 (35)	14,450 (48.5)	14,000 (56)	13,650 (61.5)	14,150 (66)	16,350 (72)
50		11,450 (24.5)	12,750 (42.5)	12,350 (52)	12,100 (58.5)	12,700 (63)	15,700 (69.5)
60			10,050 (28)	9,780 (42.5)	9,580 (51)	10,150 (57)	13,300 (65)
70				7,860 (30)	7,710 (42.5)	8,220 (50)	10,200 (60)
80					6,270 (32)	6,730 (42.5)	7,430 (55)
90					4,800 (15.5)	5,550 (33.5)	5,370 (49.5)
100						4,010 (21)	3,770 (43)
110							2,510 (36)
120							1,480 (27)
Minimum boom angle (deg.) for indicated length (no load)						0	10
Maximum boom length (ft.) at 0 degree boom angle (no load)						112	

NOTE: ( ) Boom angles are in degrees.

#LMI operating code. Refer to LMI manual for instructions.

\*This capacity is based on maximum boom angle.

+12 parts line required to lift this capacity (using aux. boom nose). Refer to Operator's and Safety Handbook for reeving diagram.

Lifting Capacities On Outriggers Fully Extended - 360° At Zero Degree Boom Angle							
Boom Angle	Main Boom Length in Feet						
	35	61	74	87	99	112	
0°	26,400 (28.2)	10,150 (53.8)	6,240 (66.6)	3,420 (79.4)	2,440 (92.2)	1,680 (105)	

NOTE: ( ) Reference radii in feet.

A6-829-100800

Ext. %							
Inner-mid	0	0	0	0	0	0	100
Center-mid	0	100	100	100	100	100	100
Outer-mid	0	0	25	50	75	100	100
Fly	0	0	25	50	75	100	100

**RATED LIFTING CAPACITIES IN POUNDS WITH 8,500 LB. COUNTERWEIGHT  
35 FT. - 138 FT. BOOM (MODE B)  
ON OUTRIGGERS FULLY EXTENDED - 360°**

Radius in Feet	#0001								
	Main Boom Length in Feet								
	35	55	61	74	87	99	112	125	138
10	+150,000 (65.5)	79,100 (76)	78,450 (77.5)	*57,050 (80)					
12	110,000 (62)	79,100 (73.5)	77,500 (75.5)	57,050 (78.5)	*43,300 (80)				
15	95,800 (56)	79,100 (70)	69,850 (72.5)	51,650 (76)	43,300 (78.5)	*32,100 (80)			
20	70,700 (44.5)	70,300 (64.5)	59,850 (67.5)	44,350 (71.5)	39,550 (75)	32,100 (77.5)	30,050 (79.5)	*20,150 (80)	
25	53,150 (29.5)	52,850 (58)	52,200 (62)	38,750 (67.5)	33,800 (71.5)	32,100 (74.5)	30,050 (77)	20,150 (79)	*19,000 (80)
30		41,400 (51)	41,800 (56.5)	34,200 (63)	29,200 (68)	30,200 (71.5)	27,350 (74.5)	19,100 (76.5)	18,300 (78.5)
35		31,850 (43.5)	31,950 (50)	29,050 (58.5)	25,800 (64)	26,600 (68.5)	24,300 (71.5)	18,100 (74)	17,650 (76.5)
40		24,700 (34.5)	24,750 (43)	24,800 (53.5)	22,900 (60)	23,450 (65)	21,600 (69)	17,250 (72)	17,000 (74)
45		19,550 (21.5)	19,550 (35)	19,750 (48.5)	19,500 (56)	20,450 (61.5)	19,250 (66)	16,450 (69)	16,350 (72)
50			15,700 (24.5)	15,400 (42.5)	15,350 (52)	16,550 (58.5)	16,900 (63)	15,750 (66.5)	15,700 (69.5)
60				9,490 (28)	9,730 (42.5)	10,800 (51)	11,900 (57)	13,000 (61.5)	13,300 (65)
70					6,020 (30)	7,040 (42.5)	8,080 (50)	9,130 (56)	10,200 (60)
80						4,390 (32)	5,390 (42.5)	6,400 (49.5)	7,430 (55)
90						2,420 (15.5)	3,390 (33.5)	4,370 (43)	5,370 (49.5)
100							1,840 (21)	2,800 (35)	3,770 (43)
110								1,550 (24.5)	2,510 (36)
120									1,480 (27)
Minimum boom angle (deg.) for indicated length (no load)								5	10
Maximum boom length (ft.) at 0 degree boom angle (no load)								112	

NOTE: ( ) Boom angles are in degrees.

#LMI operating code. Refer to LMI manual for instructions.

\*This capacity is based on maximum boom angle.

+12 parts line required to lift this capacity (using aux. boom nose). Refer to Operator's and Safety Handbook for reeving diagram.

Lifting Capacities On Outriggers Fully Extended - 360° At Zero Degree Boom Angle										
Boom Angle	Main Boom Length in Feet									
	35	55	61	74	87	99	112			
0°	26,400 (28.2)	12,500 (47.4)	10,150 (53.8)	6,240 (66.6)	3,420 (79.4)	2,060 (92.2)	1,200 (105)			

NOTE: ( ) Reference radii in feet.

A6-829-100805

Ext. %									
Inner-mid	0	50	50	75	100	100	100	100	100
Center-mid	0	25	50	75	100	100	100	100	100
Outer-mid	0	0	0	0	0	25	50	75	100
Fly	0	0	0	0	0	25	50	75	100

THIS CHART IS ONLY A GUIDE AND SHOULD NOT BE USED TO OPERATE THE CRANE. The individual crane's load chart, operating instructions and other instructional plates must be read and understood prior to operating the crane.

**31 FT. - 56 FT. FOLDING BOOM EXTENSION  
WITH 8,500 LB. COUNTERWEIGHT USING 125 FT. MAIN BOOM LENGTH  
ON OUTRIGGERS FULLY EXTENDED - 360°**

Radius in Feet	31 FT. LENGTH			56 FT. LENGTH		
	#0021	#0022	#0023	#0041	#0042	#0043
	1.5° OFFSET	25° OFFSET	45° OFFSET	1.5° OFFSET	25° OFFSET	45° OFFSET
30	*11,500 (80)					
35	11,500 (78.5)					
40	11,500 (77)	*10,000 (80)		6,950 (79.5)		
45	11,500 (75)	9,300 (78.5)	*8,000 (80)	6,780 (78.5)		
50	11,000 (73.5)	8,790 (76.5)	6,810 (78.5)	6,620 (77)		
60	10,050 (70)	7,960 (72.5)	6,490 (74.5)	6,290 (74)	*4,900 (80)	
70	9,220 (66)	7,360 (68.5)	6,400 (70.5)	5,960 (71)	4,560 (76.5)	*3,700 (80)
80	7,910 (62)	6,900 (64.5)	6,350 (66)	5,640 (67.5)	4,230 (73)	3,520 (76.5)
90	5,790 (57.5)	6,380 (60)	6,340 (61.5)	5,260 (64.5)	3,870 (69.5)	3,400 (72.5)
100	4,140 (53)	4,550 (55)	5,110 (56.5)	4,980 (60.5)	3,700 (65.5)	3,290 (68.5)
110	2,840 (47.5)	3,090 (50)	3,460 (51)	4,060 (56.5)	3,480 (61.5)	3,190 (64)
120	1,770 (41.5)	1,900 (44)		2,860 (52)	3,290 (57.5)	3,110 (59.5)
130				1,860 (47.5)	2,380 (52.5)	2,830 (54)
140				1,020 (42.5)	1,430 (47.5)	
No Load Stability Data						
Minimum boom angle (deg.) for indicated length	37	39	46	42	46	47
Maximum boom length (ft.) at 0 deg. boom angle.	99			87		

NOTE: ( ) Boom angles are in degrees.

A6-829-014542

#LMI operating code. Refer to LMI manual for operating instructions.

\*This capacity is based on maximum boom angle.

1. All capacities above the bold line are based on structural strength of boom extension and do not exceed 85% of tipping loads, in accordance with SAE J-765 NOV93.
2. 31 ft. and 56 ft. folding boom extension lengths may be used for single line lifting service only.
3. For main boom lengths less than 125 ft. with the boom extension erected, the rated loads are determined by boom angle. Use only the column which corresponds to the boom extension length and offset for which the machine is set up. For boom angles not shown, use rating of the next lower boom angle.
4. **WARNING:** Operation of this machine with heavier loads than the capacities listed is strictly prohibited. Machine tipping with boom extension occurs rapidly and without advance warning.
5. Boom angle is the angle above or below horizontal of the longitudinal axis of the boom base section after lifting rated load.
6. Capacities listed are with outriggers properly extended and vertical jacks set only.



**31 FT. - 56 FT. FOLDING BOOM EXTENSION  
WITH 8,500 LB. COUNTERWEIGHT USING 138 FT. MAIN BOOM  
ON OUTRIGGERS FULLY EXTENDED - 360°**

Radius in Feet	31 FT. LENGTH			56 FT. LENGTH		
	#0021	#0022	#0023	#0041	#0042	#0043
	1.5° OFFSET	25° OFFSET	45° OFFSET	1.5° OFFSET	25° OFFSET	45° OFFSET
35	9,500 (79.5)					
40	9,500 (78)			*5,500 (80)		
45	9,500 (76.5)	*8,750 (80)		5,400 (79.5)		
50	9,500 (75)	7,490 (78.5)	*7,800 (80)	5,300 (78)		
60	9,110 (71.5)	7,060 (75)	6,740 (77)	5,100 (75.5)	*4,640 (80)	
70	8,450 (68.5)	6,720 (71.5)	6,460 (73.5)	4,900 (72.5)	4,430 (78)	*3,600 (80)
80	7,550 (64.5)	6,330 (68)	6,350 (69.5)	4,700 (69.5)	4,220 (74.5)	3,500 (77.5)
90	6,200 (60.5)	6,060 (64)	6,280 (65.5)	4,500 (66.5)	4,120 (71)	3,400 (74)
100	4,530 (56.5)	5,330 (60)	5,580 (61)	4,300 (63.5)	3,810 (67.5)	3,300 (70.5)
110	3,200 (52)	3,860 (55.5)	3,970 (56.5)	4,100 (59.5)	3,600 (64)	3,200 (67)
120	2,120 (47)	2,660 (50.5)	2,660 (52)	3,120 (56)	3,400 (60.5)	3,100 (63)
130	1,220 (41.5)	1,660 (45)		2,150 (52)	2,640 (56)	3,000 (58.5)
140				1,320 (47.5)	1,640 (51.5)	1,920 (53.5)
<b>No Load Stability Data</b>						
Minimum boom angle (deg.) for indicated length	39	44	45	47	49	50
Maximum boom length (ft.) at 0 deg. boom angle	99			87		

NOTE: ( ) Boom angles are in degrees.

A6-829-014543A

#LMI operating code. Refer to LMI manual for operating instructions.

\*This capacity is based on maximum boom angle.

- All capacities above the bold line are based on structural strength of boom extension and do not exceed 85% of tipping loads, in accordance with SAE J-765 NOV93.
- 31 ft. and 56 ft. folding boom extension lengths may be used for single line lifting service only.
- For main boom lengths between 125 ft. and fully extended with the boom extension erected, the rated loads are determined by boom angle. Use only the column which corresponds to the boom extension length and offset for which the machine is set up. For boom angles not shown, use rating of the next lower boom angle.
- WARNING:** Operation of this machine with heavier loads than the capacities listed is strictly prohibited. Machine tipping with boom extension occurs rapidly and without advance warning.
- Boom angle is the angle above or below horizontal of the longitudinal axis of the boom base section after lifting rated load.
- Capacities listed are with outriggers properly extended and vertical jacks set only.

THIS CHART IS ONLY A GUIDE AND SHOULD NOT BE USED TO OPERATE THE CRANE. The individual crane's load chart, operating instructions and other instructional plates must be read and understood prior to operating the crane.

**31 FT. - 56 FT. LUFFING FOLDING BOOM EXTENSION  
WITH 8,500 LB. COUNTERWEIGHT USING 125 FT. MAIN BOOM LENGTH  
ON OUTRIGGERS FULLY EXTENDED - 360°**

Radius in Feet (reference)	31 FT. LENGTH			56 FT. LENGTH		
	#0910	#0911	#0912	#0920	#0921	#0922
	1.5° OFFSET	25° OFFSET	45° OFFSET	1.5° OFFSET	25° OFFSET	45° OFFSET
30	*11,000 (80)					
35	11,000 (78.5)					
40	11,000 (77)	*10,000 (80)		6,450 (79.5)		
45	11,000 (75)	9,300 (78.5)	*8,000 (80)	6,450 (78.5)		
50	11,000 (73.5)	8,790 (76.5)	6,810 (78.5)	6,450 (77)		
60	10,050 (70)	7,960 (72.5)	6,490 (74.5)	6,290 (74)	*4,900 (80)	
70	9,220 (66)	7,360 (68.5)	6,400 (70.5)	5,960 (71)	4,560 (76.5)	*3,700 (80)
80	7,780 (62)	6,900 (64.5)	6,350 (66)	5,640 (67.5)	4,230 (73)	3,520 (76.5)
90	5,630 (57.5)	6,170 (60)	6,320 (61.5)	5,260 (64.5)	3,870 (69.5)	3,400 (72.5)
100	3,960 (53)	4,370 (55)	4,340 (56.5)	4,980 (60.5)	3,700 (65.5)	3,290 (68.5)
110	2,590 (47.5)	2,940 (50)	2,700 (51)	3,630 (56.5)	3,480 (61.5)	3,190 (64)
120	1,480 (41.5)	1,780 (44)		2,500 (52)	3,290 (57.5)	3,110 (59.5)
130				1,570 (47.5)	2,300 (52.5)	2,590 (54)
140					1,290 (47.5)	
<b>No Load Stability Data</b>						
Minimum boom angle (deg.) for indicated length	37	39	46	42	46	47
Maximum boom length (ft.) at 0 deg. boom angle.	87			74		

NOTE: ( ) Boom angles are in degrees.

A6-829-100355

#LMI operating code, for reference only (does not require input - automatically displayed). Refer to LMI manual for operating instructions.

\* This capacity is based on maximum boom angle.

- Capacities are based on main boom angles in conjunction with extension offset angle. Radii are for 125' main boom length only.
- All capacities above the bold line are based on structural strength of boom extension and do not exceed 85% of tipping loads, in accordance with SAE J-765.
- 31 ft. and 56 ft. luffing folding boom extension lengths may be used for single line lifting service only.
- For main boom lengths less than 125 ft. with the boom extension erected, the rated loads are determined by boom angle. Use only the column which corresponds to the boom extension length and offset for which the machine is set up. For boom angles not shown, use rating of the next lower boom angle. For extension offset angles not shown, use rating of next greater offset angle.
- WARNING:** Operation of this machine with heavier loads than the capacities listed is strictly prohibited. Machine tipping with boom extension occurs rapidly and without advance warning.
- Boom angle is the angle above or below horizontal of the longitudinal axis of the boom base section after lifting rated load.
- Capacities listed are with outriggers properly extended and vertical jacks set only.

**31 FT. - 56 FT. LUFFING FOLDING BOOM EXTENSION  
WITH 8,500 LB. COUNTERWEIGHT USING 138 FT. MAIN BOOM  
ON OUTRIGGERS FULLY EXTENDED - 360°**

Radius in Feet (reference)	31 FT. LENGTH			56 FT. LENGTH		
	#0910	#0911	#0912	#0920	#0921	#0922
	1.5° OFFSET	25° OFFSET	45° OFFSET	1.5° OFFSET	25° OFFSET	45° OFFSET
35	9,500 (79.5)					
40	9,500 (78)			*5,500 (80)		
45	9,500 (76.5)	*8,750 (80)		5,400 (79.5)		
50	9,500 (75)	7,490 (78.5)	*7,800 (80)	5,300 (78)		
60	9,110 (71.5)	7,060 (75)	6,740 (77)	5,100 (75.5)	*4,640 (80)	
70	8,450 (68.5)	6,720 (71.5)	6,460 (73.5)	4,900 (72.5)	4,430 (78)	*3,600 (80)
80	7,550 (64.5)	6,330 (68)	6,350 (69.5)	4,700 (69.5)	4,220 (74.5)	3,500 (77.5)
90	5,600 (60.5)	6,060 (64)	6,160 (65.5)	4,500 (66.5)	4,120 (71)	3,400 (74)
100	4,020 (56.5)	5,030 (60)	5,220 (61)	4,300 (63.5)	3,810 (67.5)	3,300 (70.5)
110	2,760 (52)	3,470 (55.5)	3,590 (56.5)	3,950 (59.5)	3,600 (64)	3,200 (67)
120	1,740 (47)	2,200 (50.5)	2,270 (51)	2,820 (56)	3,400 (60.5)	3,100 (63)
130		1,140 (45)		1,780 (52)	2,580 (56)	2,940 (58.5)
140					1,600 (51.5)	1,880 (53.5)
<b>No Load Stability Data</b>						
Minimum boom angle (deg.) for indicated length	39	44	45	47	49	50
Maximum boom length (ft.) at 0 deg. boom angle	87			74		

NOTE: ( ) Boom angles are in degrees.

A6-829-100349

#LMI operating code, for reference only (does not require input - automatically displayed). Refer to LMI manual for operating instructions.

\*This capacity is based on maximum boom angle.

1. Capacities are based on main boom angle in conjunction with extension offset angle. Radii are for 138 ft. main boom length only.
2. All capacities above the bold line are based on structural strength of boom extension and do not exceed 85% of tipping loads, in accordance with SAE J-765.
3. 31 ft. and 56 ft. luffing folding boom extension lengths may be used for single line lifting service only.
4. For main boom lengths between 125 ft. and fully extended with the boom extension erected, the rated loads are determined by boom angle. Use only the column which corresponds to the boom extension length and offset for which the machine is set up. For boom angles not shown, use rating of the next lower boom angle. For extension offset angles not shown, use rating of next greater offset angle.
5. **WARNING:** Operation of this machine with heavier loads than the capacities listed is strictly prohibited. Machine tipping with boom extension occurs rapidly and without advance warning.
6. Boom angle is the angle above or below horizontal of the longitudinal axis of the boom base section after lifting rated load.
7. Capacities listed are with outriggers properly extended and vertical jacks set only.

## TMS875C Features and Benefits



- ▶ Standard front and rear air ride suspension provides comfortable ride at max speed of 65 mph



- ▶ Electronically controlled Cummins six cylinder, turbo charged, 400 bhp diesel -- highest in 75 ton class

- ▶ Optional luffing swingaway for five section boom offers ability to offset in air under load



- ▶ Both carrier and operator's cab constructed from galvanized metal and finished with Imron 5000 to improve longevity

Hot water cab heater/defrosters also standard in both cabs



Constant improvement and engineering progress make it necessary that we reserve the right to make specification, equipment, and price changes without notice. Illustrations shown may include optional equipment and accessories and may not include all standard equipment.

GROVE® and GROVE LOGO are registered trademarks of GROVE in the U.S. and/or other countries. Copyright© 2000 GROVE. All rights reserved.

### Grove Worldwide - World Headquarters

1565 Buchanan Trail East

P.O. Box 21

Shady Grove, Pennsylvania 17256-0021, U.S.A.

Tel: (717) 597-8121

Fax: (717) 597-4062

[www.groveworldwide.com](http://www.groveworldwide.com)